

# LIQUID WITHDRAWAL DEVICE



For Liquid Nitrogen LD25, LD35 and LD50 Dewars



The Liquid Withdrawal Device (LWD) provides convenient pressure transfers of liquid nitrogen from LD25, LD35 and LD50 Dewars. The device clamps directly to the special neck flange that is found under the plastic trim collar around the neck of these containers. Flow rates up to 8 liters per minutes are possible at operating pressures up to 6.5 psig (0.45 bar/45 kPa). Liquid can be dispensed directly from the LWD via the spout provided, or through a standard cryogenic hose connected to the liquid outlet.

## SAFETY

Before using this equipment, read these instructions carefully. Also, read and understand the instructions supplied with your Dewar and the Handle with Care booklet packed with all Liquid Nitrogen Dewars. The Handle with Care booklet gives detailed information on the safe handling of liquid nitrogen. Additional copies of these publications can be obtained from your supplier. Do not modify LWD or Dewar or use in a manner other than that described in accompanying instructions and documentation.

Contact with liquid nitrogen or cold gas may cause serious freezing (frostbite) injury. Do not touch liquid or cold metal surfaces with your bare skin. Always wear a face shield and gloves when transferring liquid nitrogen.

Nitrogen gas can cause suffocation without warning. In a confined area, nitrogen gas from this equipment may displace air required for breathing. Store and use this equipment only in well-ventilated areas.

Use only containers designed for low-temperature liquids. Cryogenic containers should be filled SLOWLY to minimize stresses which can damage the container.

Vent all pressure from a Dewar before attempting to remove the Liquid Withdrawal Device. If the band clamp securing the LWD to a Dewar is loosened while there is pressure in the Dewar, cold gas or liquid could be expelled causing personal injury.

Liquid Withdrawal Device is for use with liquid nitrogen only. LWD is for use on specific ICBiomedical Dewars - Models LD25, LD35 and LD 50.

Pressure in Dewar with LWD installed should never exceed 6.5 psig (0.45 bar/45 kPa). Fill Dewar from supply source at 22 psig (1.52 bar/152 kPa) or less. Do not pressurize using compressed air.

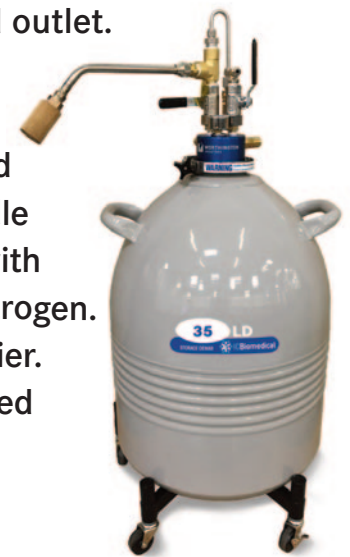

# LIQUID WITHDRAWAL DEVICE



## INSTALLATION

1. Remove the necktube cap/core from the Dewar
2. Remove 3 flat-head mounting screws in the base of the plastic trim collar around the neck of the Dewar, remove the collar and discard or save for later. It is not used while the LWD is installed.

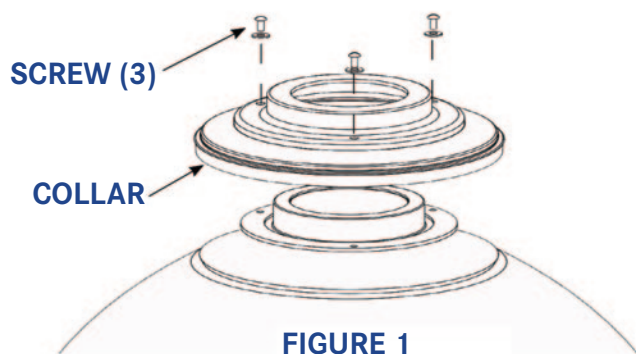

3. The liquid withdrawal tube (the longer of the two plastic tubes) is scored approximately 6 in. (152 mm) from the end. This tube must be shortened for use with a LD25 or LD35 Dewar by breaking off the 6 in. (152 mm) section. Discard the 6 in. (152 mm) piece. The tube is used as supplied with the LD50.
4. Insert the longer plastic tube into the underside of the flange assembly, beneath the LIQUID valve. Insert the shorter plastic tube into the threaded fitting on the underside of the flange assembly, beneath the VENT valve. Tighten the compression nuts with a wrench to secure.

5. Position the safety cable assembly around the top of the Dewar, underneath the flange. Loosen V-Band Clamp until the clamp is large enough to remove from the LWD. Drop the band clamp around the flange on the Dewar (see Figure 2 on next page).
6. Clean the flange O-ring and apply a thin layer of silicone grease before placing it on the grooved flange.
7. NOTE: Be sure flange surfaces are warm, clean and dry. The O-ring must be cleaned and lightly lubricated before installing the LWD.
8. Carefully lower the LWD unit into the Dewar. The LWD should rest firmly centered on the neck flange of the Dewar; the liquid withdrawal tube should not touch the bottom of the Dewar.
9. Place the band clamp around the flange of both the LWD unit and the Dewar. Be sure that the clamp is properly engaged on both flanges. Tighten the clamp – hand tighten only.
10. Attach the snap of the safety cable to the ring on the LWD (see figure 2 next page).
11. If the spout assembly is to be used, install it on the outlet fitting above the LIQUID valve. The phase separator will ensure a controlled flow of liquid.

855.750.8191 | [sales@ICBiomedical.com](mailto:sales@ICBiomedical.com)  
[www.ICBiomedical.com](http://www.ICBiomedical.com)  
Made In USA

# LIQUID WITHDRAWAL DEVICE



## OPERATION

**Filling** – It is not necessary to remove the LWD unit from the Dewar for filling. You may fill the Dewar by pressure-transfer of liquid nitrogen through the LIQUID valve of the LWD.

**WARNING:** Over pressurization of the Dewar could result in serious bodily injury or property damage. Never exceed the 6.5 psig (0.45 bar/45 kPa) relief valve pressure setting of the LWD.

To fill, remove the spout assembly and connect a 22 psig (1.52 bar/152 kPa) or lower pressure liquid supply cylinder to the withdrawal device using a liquid nitrogen transfer hose with female CGA 295 connections on both ends.

**WARNING:** The transfer hose must be used with a pressure relief valve to prevent excessive pressure build-up in the hose when the valves are closed at both ends of the hose. If liquid nitrogen is trapped between the valves of the liquid cylinder and the LWD, it has no escape path as it warms and expands. The resulting pressure can cause the hose to rupture and may cause personal injury. The current model LWD is equipped with a pressure relief valve. Previous versions of the LWD must be used with a transfer hose equipped with a pressure relief valve.

Once the transfer hose is connected, open the LWD VENT valve first and then open the LWD LIQUID valve. Then slowly open the

liquid valve on the supply cylinder until liquid flow is established. Adjust the VENT valve to maintain a back pressure of 6.5 psig (0.45 bar/45 kPa) or less in the Dewar. When liquid sputters from the VENT valve, quickly close the liquid valve on the supply cylinder, next the LWD LIQUID valve and then the LWD VENT valve.

**WARNING:** Closely monitor Dewar pressure throughout the fill process. Never let the pressure exceed 6.5 psig (0.45 bar/45 kPa). If the pressure approaches 6.5 psig (0.45 bar/45 kPa), immediately fully open the LWD VENT valve and/or close the LWD LIQUID valve as necessary to control the pressure in the Dewar.

Loosen the hose connection slowly and allow all pressure and any remaining liquid to dissipate before completely disconnecting the hose.

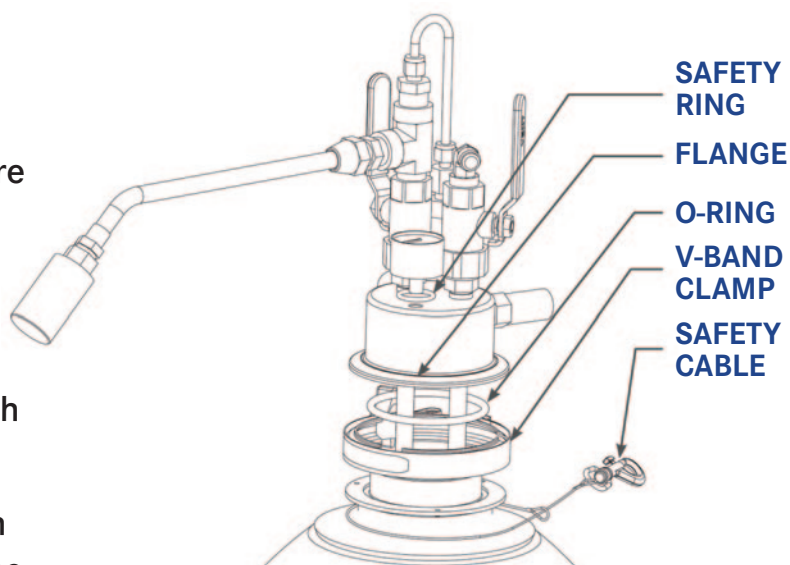

FIGURE 2

# LIQUID WITHDRAWAL DEVICE



The primary relief valve, set at 6.5 psig (0.45 bar/45 kPa), maintains the normal operating pressure of the LWD. A secondary relief valve, set at 6.5 psig (0.45 bar/45 kPa), prevents hazardous pressure rise in the event of primary relief valve malfunction or if its capacity is exceeded. Never replace either of these parts with higher value relief valves; increasing the pressure in the Dewar beyond 6.5 psig (0.45 bar/45 kPa) may burst the Dewar and cause personal injury/property damage.

To fill the Dewar by pouring liquid from another container, ([This is not the recommended filling method](#)) first open the VENT valve to release pressure. Then, loosen the band clamp, unsnap the safety cable, and remove the LWD unit. When replacing the

LWD on the filled Dewar, leave the VENT valve open until the flanges are securely clamped.

**Note:** Be sure flanges surfaces are warm, clean and dry. The O-ring must be cleaned and lightly lubricated before replacing the LWD.

**Liquid Withdrawal** – when the liquid valve is opened, pressure in the Dewar forces liquid to go up through the withdrawal tube and out through the valve. The liquid nitrogen can be dispensed through the spout or through the transfer hose connected to the liquid outlet.

**Pressure Building** – If the Dewar is filled properly, liquid nitrogen evaporation will maintain a pressure sufficient to sustain liquid withdrawal.

855.750.8191 | [sales@ICBiomedical.com](mailto:sales@ICBiomedical.com)  
[www.ICBiomedical.com](http://www.ICBiomedical.com)  
Made In USA

# LIQUID WITHDRAWAL DEVICE

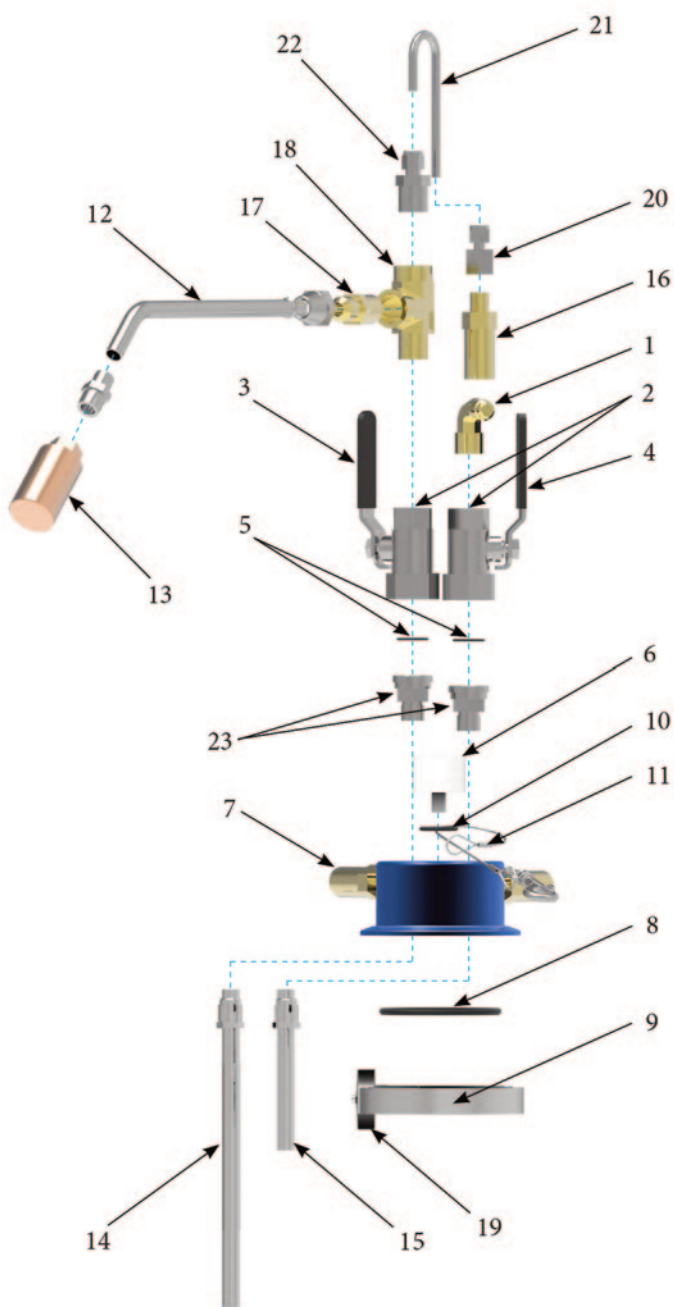

Item	Description	Part
1	Elbow, Vent	6814-9225
2	Valve (Liquid/Vent)	6986-9004
3	Valve Handle Cover, Liquid	373608
4	Valve Handle Cover, Vent	373607
5	O-Ring for Valve	8830-6142
6	Pressure Gauge 0-15 psig	7702-6095
7	Relief Valve 6.5 psig (0.45 bar/45 kPa)	6913-9095
8	O-Ring for Flange	8830-6135
9	V-Band Clamp, w/Warning Label	D050-8C12
10	Ring for Safety Cable	8830-6315
11	Safety Cable Assembly	D050-8C20
12	Spout Assembly	D050-8C14
13	Phase Separator	1193-8C80
14	Withdrawal Tube Assembly	D050-8C37
15	Vent Tube Assembly	D050-8C39
16	Relief Valve 22 psig (2.4 bar/24 kPa)	6913-9069
17	Connector, CGA 295 x 1/2" FTP	7355-4698
18	Street Tee, 1/2" NPT	6916-9210
19	V-Band Clamp Tightening Knob	7342-1125
20	Connector, 1/4" ODT x 1/4" FTP	45701930
21	Tube, Relief	D050-9C10
22	Connector, 1/4" ODT x 1/2" MPT	45701929
23	Valve Adapter	D050-8C29

**Ordering Information** – Order all replacement parts and accessories from your distributor.

Please include the part and model number of your dewar, quantity, and description of each part requested.

For more information, contact ICBiomedical at the address listed.

855.750.8191 | [sales@ICBiomedical.com](mailto:sales@ICBiomedical.com)

[www.ICBiomedical.com](http://www.ICBiomedical.com)

Made In USA